

UNMANNED SURVEILANCE VESSEL

USV MK2

DESIGN REGISTERED/ PATENT PENDING



Naval Design

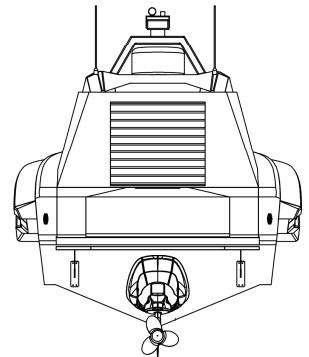
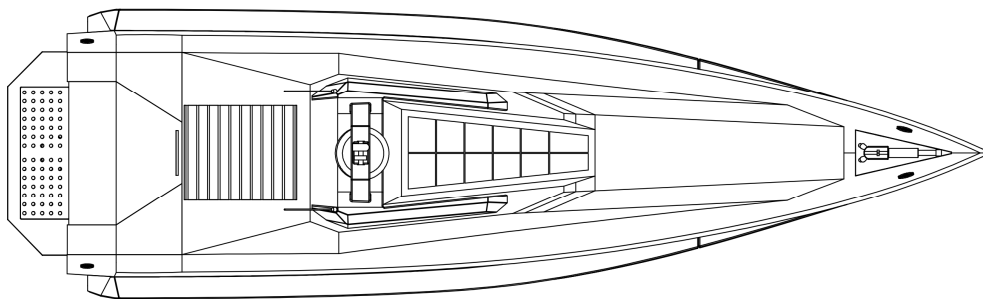
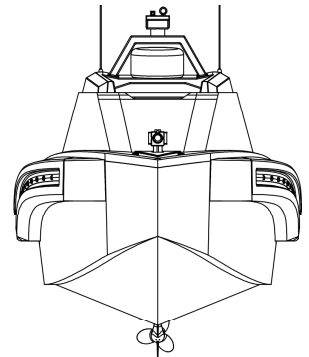
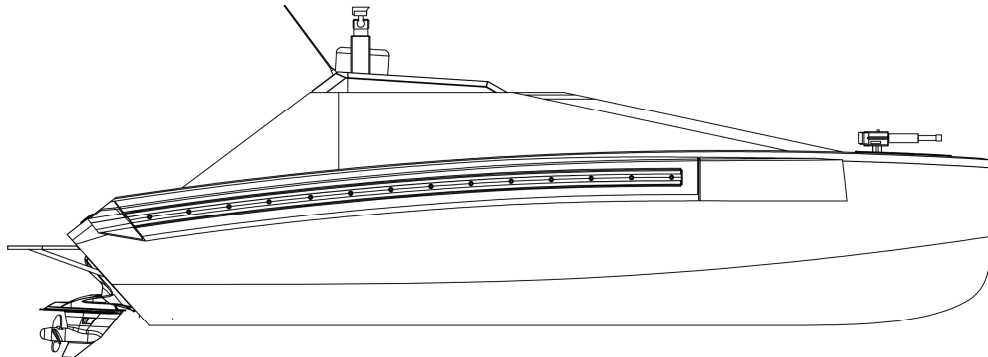

Dimensional Data

Length Overall	8.7 m
Beam overall	2.7 m
Displacement	4.3 t
Fuel capacity	1500 L
Speed max	55 knots
Speed at cruise speed	38 knots
Range at cruise speed	1087 Nm
Crew	0
Passengers	6
Load capacity	
Draft	0.43m
Design Vessel	KND
Design Radar Communication	Prof. A Atkinson
Design Control System	Prof. A Hamman

Engine Data

Max Power Caudwell Axis Drive 350Hp Diesel

Options And Accessories

- Armament deployment / Fire control system with stabilized platform
- Self destruction device from Remote control

Standard Features

- Fully integrated Radar system
- Loud-hailer
- Electro Optical Director (EOD)
- 360 Deg panoramic camera
- Forward Looking Infrared sensor (FLIR)
- Color Charge- Couple device camera (CCD)
- Laser range finder (LRF)
- Tracking device via satellite
- Fire extinguishers system
- Depth finder
- Electric and manual bilge pumps
- Foam floatation
- Electronics distribution panel
- Steel grab-rails
- Remote and manual control opening doorway
- Engine protection gearbox / platform
- Self Righting vessel
- Stealth exterior Design profile
- Solar panels for charging battery bank system
- Construction – Aluminum Alloy with HD Fendering system

Classification

- To meet client's demand

ADDRESS

Studio 403, Old Castle Brewery
6 Beach Road, Woodstock
Cape Town, 8000, South Africa

TELEPHONE
FACSIMILE

+27 (0) 21 448 9464
+27 (0) 21 447 9468

EMAIL
WEBSITE

info@navaldesign.com
www.navaldesign.com

*Please note that this is a non contractual document.
We reserve the right to make changes without notice.